

FPF20KGU115BER-120

standard with fan

> CONTACT US



FPF series exhaust filter and filter fans represents a side-mounted cooling solution with filtered ambient air to maintain optimum ventilation inside the electrical cabinets. These units have a flat external profile and a quick snap-on fastening system with elastic hooks. Available in different range of sizes, airflow ratings and configurations.

| Technical data | | |
|-------------------------|--------------------------|---------------------|
| APPROVALS | | |
| Approvals | CE; UKCA | |
| PERFORMANCE | | |
| Max Airflow | 660/745 | m ³ /h |
| | 388/438 | CFM |
| Max Static Pressure | 220/222 | Pa |
| | 0.88/0.89 | in H ₂ O |
| ELECTRICAL DATA | | |
| Rated Voltage | 115 | V a.c. |
| Rated Current | 0.96/1.3 | A |
| Rated Power | 107/143 | W |
| Operating Voltage | 103.5-126.5 | V a.c. |
| Frequency | 50/60 | Hz |
| Appliance Class | I | |
| Motor Protection | Thermally Protected | |
| MECHANICAL DATA | | |
| Mounting Wall Thickness | 1.5-2.2 | mm |
| | 0.06-0.09 | in |
| GENERIC DATA | | |
| RAL Number | 7035 | |
| Airflow Direction | Reverse | |
| Electrical Connection | Screwless Terminal Block | |

Image is for illustrative purpose only. All specifications, data and drawing are subject to change without notice. Please refer to our terms of sales including our warranty and limited liabilities clauses.

FPF20KGU115BER-120

standard with fan

> CONTACT US

| Technical data | | |
|--------------------------------|---|-----------------|
| Life Expectancy | 70000 | h at 25 °C |
| | 70000 | h at 77 °F |
| Wires Section | 0.75-2.5 | mm ² |
| Wires Section | 20-14 | AWG |
| Fan Noise | 74.7/78.9 | dB(A) |
| Filter Class | G3 | EN 779 |
| Filter Class | ISO coarse 55% | ISO 16890 |
| Filter Material | thermo-linked progressive structure synthetic fibre | |
| ENVIRONMENTAL AND THERMAL DATA | | |
| IP Protection Degree | IP54 | |
| Operating Temperature | -10÷55 | °C |
| | 14÷131 | °F |
| Storage Temperature | -30÷75 | °C |
| | -22÷167 | °F |

Image is for illustrative purpose only. All specifications, data and drawing are subject to change without notice. Please refer to our terms of sales including our warranty and limited liabilities clauses.

FPF20KGU115BER-120

standard with fan

> CONTACT US

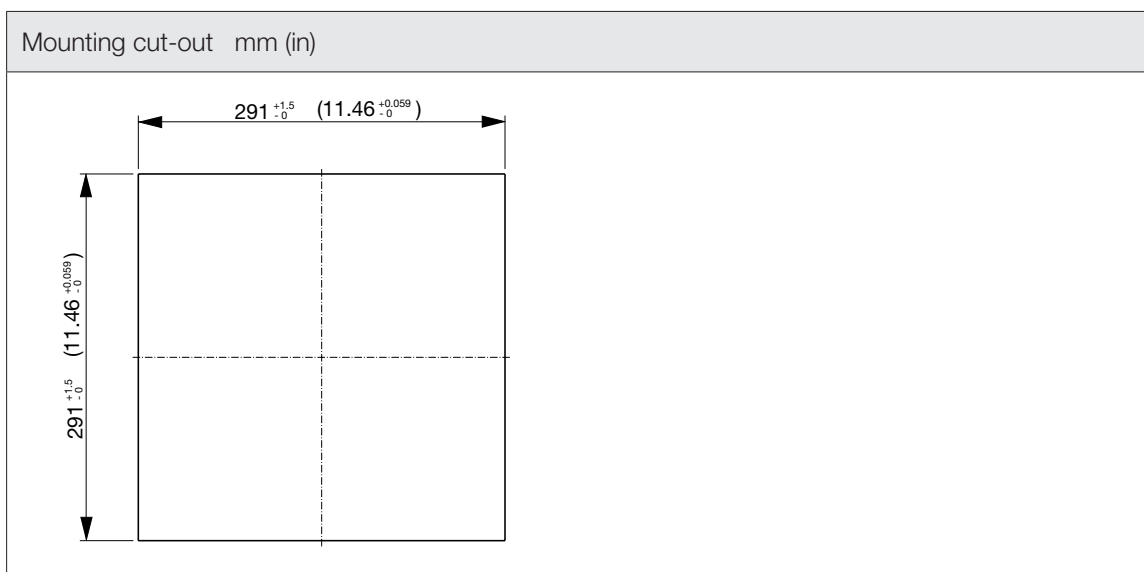
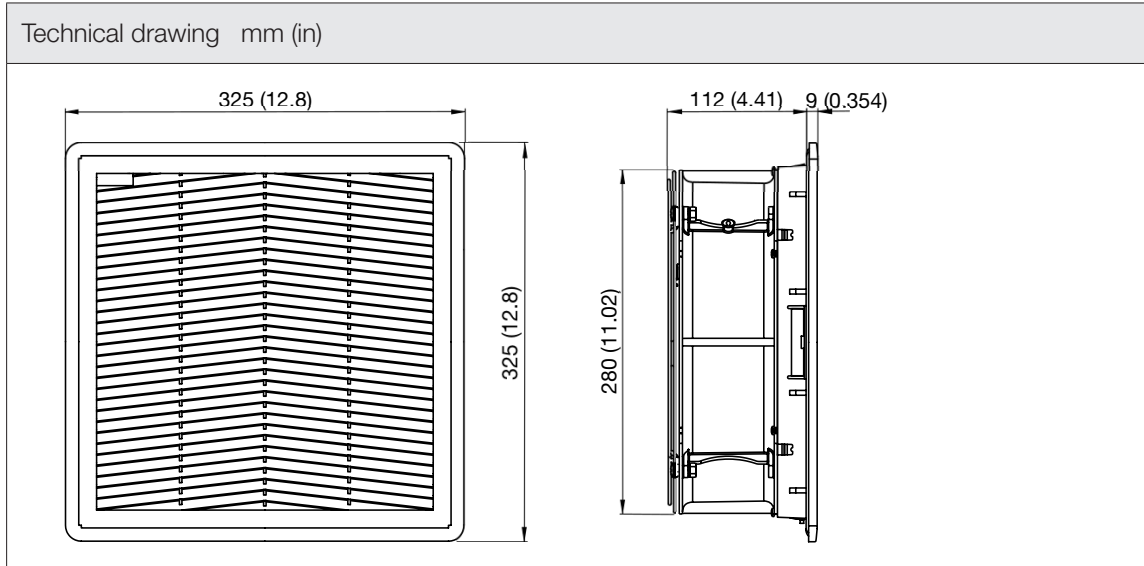

Image is for illustrative purpose only. All specifications, data and drawing are subject to change without notice. Please refer to our terms of sales including our warranty and limited liabilities clauses.

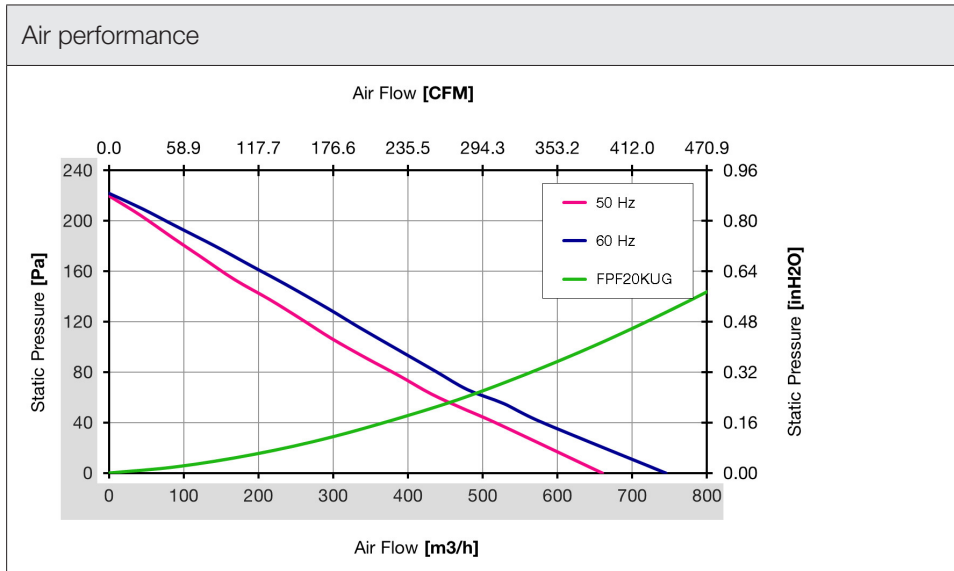

Image is for illustrative purpose only. All specifications, data and drawing are subject to change without notice. Please refer to our terms of sales including our warranty and limited liabilities clauses.